



Display Systems

T3 Wandlight

Product Brochure v3



Designed and Produced by
TECNA DISPLAY LTD

T3 Wandlight

THE VIRTUALLY UNBREAKABLE, NON GLASS, BRIGHT, WHITE LIGHT THAT YOU HAVE BEEN LOOKING FOR.

Finding a feather weight, durable and portable tube light that emits a bright, white light has always been difficult in the exhibition and display industry, this is what has brought about the invention of the T3 Wandlite.

Its patented design allows for the T3 Wandlight to emit revolutionary 360° light that makes it one of the most versatile and innovative lighting products available.

No other LED comes close to offering the same

TWIST
LOCK &
CONNECT

T3
Display Systems



KEY FEATURES

- BRIGHT, WHITE, 360° LED TUBE LIGHT
- LIGHTWEIGHT, DURABLE AND PORTABLE DESIGN
- PERFECT FOR EXHIBITION AND RETAIL DISPLAY LIGHTING
- BROAD RANGE OF ACCESSORIES
- WATERPROOF AND DUSTPROOF
- PRODUCED IN ANY LENGTH FROM 250MM TO 2400MM
- MULTIPLE POWERING SOURCES

FEATURES

WHY USE T3 WANDLIGHT?

No other LED tube light comes close to offering the same benefits that the Wandlite affords to the display and exhibition industry. Here are just some of the key features that make up the T3 Wandlite...

360° LIGHTING

Registered as a Class III Luminaire, the T3 Wandlite is the only tube light of its kind that provides a non flickering, bright, white light in a 360 degree capacity.



UNBREAKABLE

Its lightweight, robust design and construction makes it a virtually unbreakable LED tube light.



SIMPLE TO INSTALL

Its broad range of versatile mounting options allows it to be installed quickly and easily into virtually any display structure.



WATERPROOF & DUSTPROOF

The unique design of the T3 Wandlite allows it to be a waterproof and dustproof light. Independently tested to an IP65 rating.



SIMPLE TO POWER

It can be fitted to use multiple powering sources from off grid and on grid supplies. Sources include solar panels, batteries and cigarette car sockets



ECO-FRIENDLY

Its low power usage and 70,000 hour life span make the T3 Wandlite one of the most eco-friendly tube lights available.



i INFO

T3 Wandlight is manufactured within the UK and meets all EU manufacturing standards.



KEY FEATURE

The T3 Wandlight has mounting accessories that are compatible with all T3 framework systems.

CUSTOM & STANDARDS

T3 WANDLITES VERSATILITY COMES IN THE ABILITY TO ILLUMINATE ANY SIZE OF DISPLAY AND CREATE UNIQUE BRANDING OPPORTUNITIES

Our tubes can be cut to any length to accommodate small to large display lighting requirements. With its simple to follow powering configurations, easy installation methods and accessories, it really can be a revolutionise how you light your displays.

The T3 Wandlite can be branded to suit your corporate colours, with our LED tubes also available in RGB multicolour lights it provides you with a unique branding opportunity for your next event. All our multi-coloured tubes can be cut to bespoke lengths making it a truly unique solution.

CUSTOM SIZES

*Sizes from 0.4m-3m

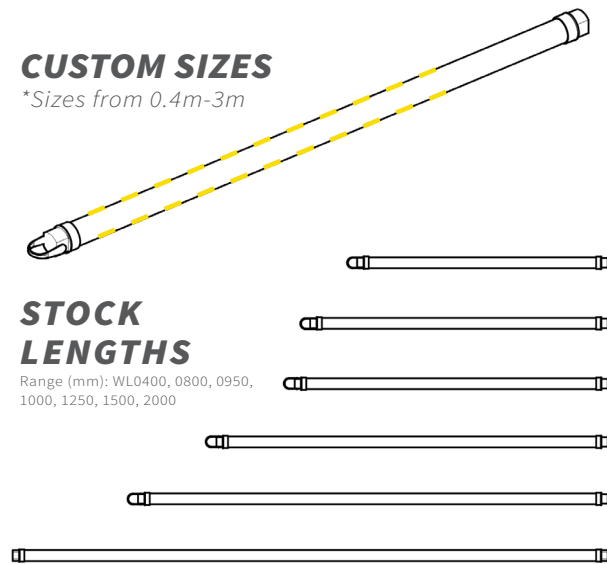

STOCK LENGTHS

Range (mm): WL0400, 0800, 0950, 1000, 1250, 1500, 2000

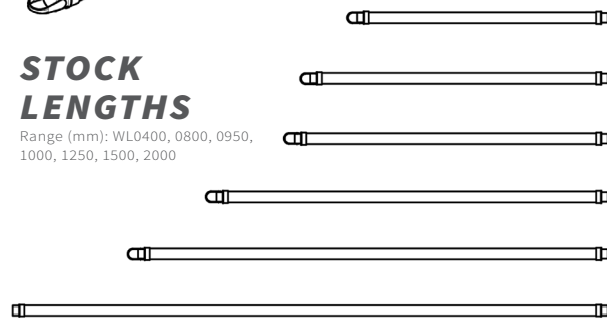

i INFO

RGB coloured T3 Wandlight tubes are available. With a remote to control your colouring.

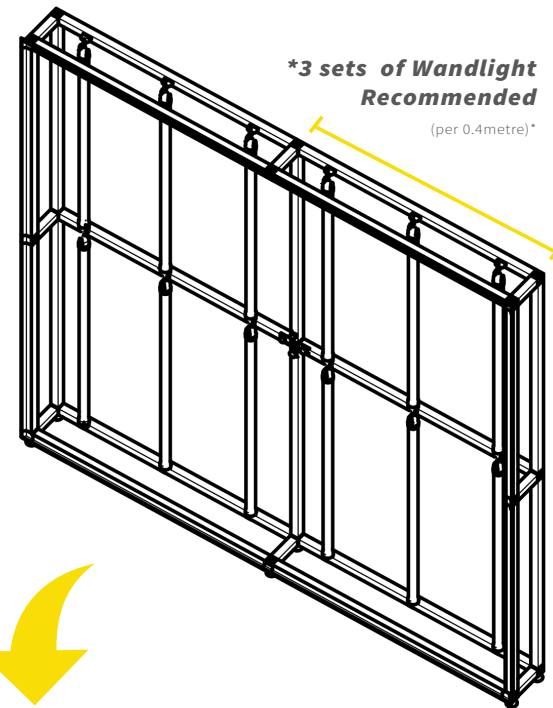

***200mm Minimum Depth Recommended**

(Dependent on material luminance)*

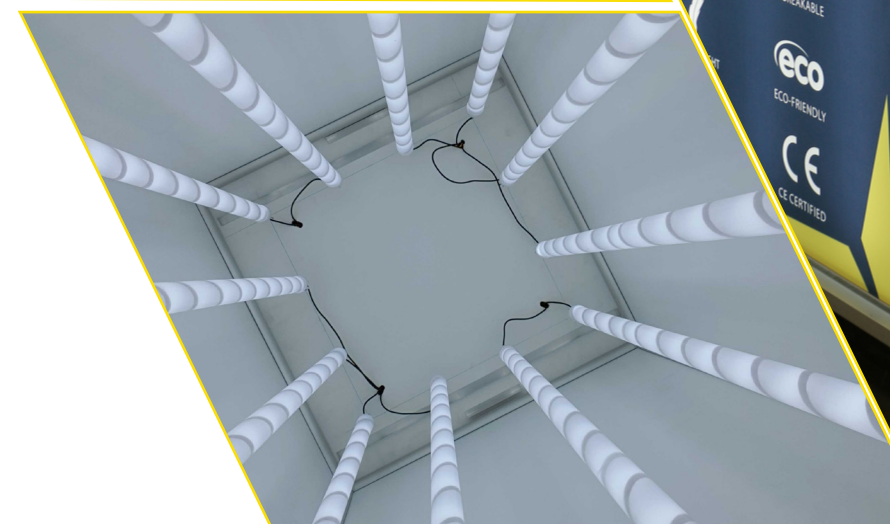
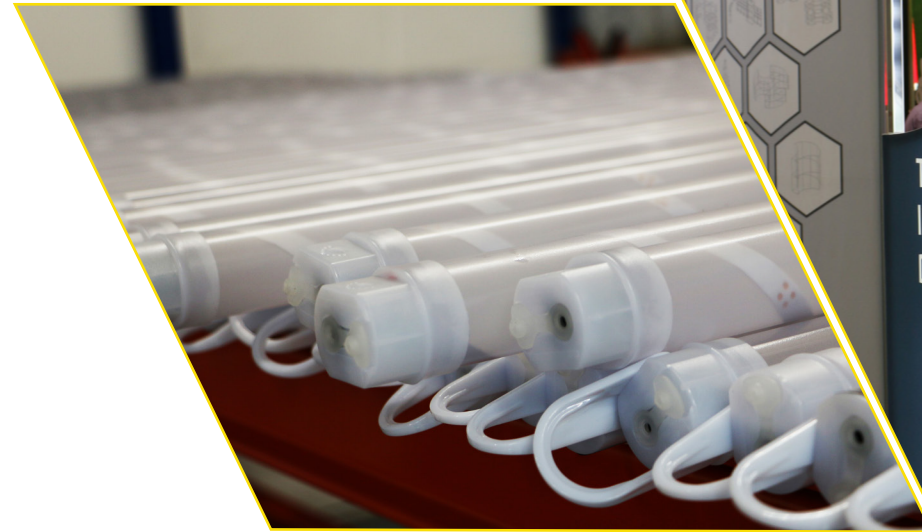

INDUSTRIES

HASSLE FREE ILLUMINATION FOR ALL YOUR DISPLAY STRUCTURES.

From counters and towers to full exhibition stands and product displays the T3 Wandlite can be used to create a brilliant, bright, white light to illuminate it all.

BARS & COUNTERS

Being durable, lightweight and providing a bright, white light makes it ideal for the display industry. Also having a huge life span and drawing minimal amounts of power makes it a cost effective and eco-friendly solution.

PRODUCT LIGHTING

Its bright, white light will help to create effective lighting to enhance your product displays. Also its varying lengths means that they is a solution for any sizes or type of display design.

TOWERS & SIGNAGE

These structures are often difficult to illuminate due to height and installation difficulties. Due to the T3 Wandlites custom sizes, linking abilities and various installation accessories means that these problems are easily resolved.

DISPLAY FEATURES

Its simple yet elegant design allows the T3 Wandlite to be used for experiential displays as well as feature pieces such as chandeliers or linked lamp posts.

TENSION FABRIC WALLS

Large backlight textile walls at events and conferences can become focal point for the audience. Not only does the T3 Wandlite illuminate the graphic display but also provides a flawless light source for the room. Its ability to be quickly linked and giving off minimal heat it is a fantastic option for large, environment friendly venues.

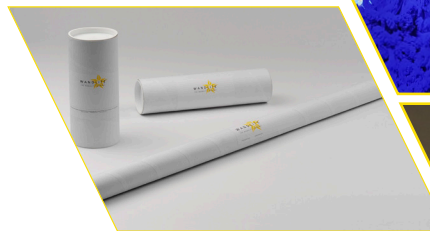

PACKAGING

Due to T3 Wandlites plastic design and unique packaging it is safe to transport without fear of breakage or damage.



i INFO

All wandlites come fitted with a single suspension hook for easy attachment.



KEY FEATURE

Daisy chain multiple T3 Wandlight tubes together for larger lighting solutions.

(view our technical details for configurations)

INSTALLATION

WANDLITES CAN BE ATTACHED IN MANY WAYS

One of the key benefits of the T3 Wandlight and its versatility in illuminating displays is in its multiple accessories. These accessories can be used singularly or in combination to create multiple configurations for the installation of the LED tube.

Z STAND CODE: WLSZ

The Z stand allows for the T3 Wandlight to be free standing by positioning it in a vertical orientation. This is the ideal method for illuminating bars, counters and plinths.



STICK LIGHT BRACKET HOOK ON

CODE: SLBH

This bracket hooks over virtually any framework. The light tube then clips securely into place with the fixing clip below. Can be used in unison with suspension hanges and 'C' hooks.



STICKER HOOK CODE: WLTAH

Sticks onto any surface, providing a secure base for the Wandlight suspension hook to be attached too. Ideal for suspending lights in counters, bars and plinths.



T BRACKET CODE: SLB

The bracket is mounted between horizontal beams of a framework. The T3 Wandlight is then clipped into place. This allows it to be adjusted and positioned to get the best light onto your graphic.



FIXING CLIP CODE: WLCFC

This accessory allows for the T3 Wandlight to be mounted onto any framework or any surface. It is secured into place using a screw or rivet and then allows for the tube to be clipped into place.



'C' HOOK CODE: WLHK-C40/100

Hook's allow for T3 Wandlight's to be suspended from our Channel Shelf support twist in. Coming in two variations which allows for tube to be hung at different lengths depending on requirements.

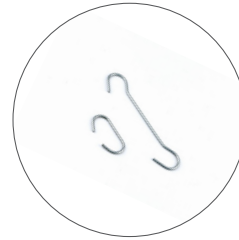

i INFO

A Wandlight can be re-purposed or reused for multiple projects and displays

KEY FEATURE

The T3 Wandlight has a 70,000 hour life span, which makes it a very cost effective and eco-friendly solution.

POWER

THE T3 WANDLITE HAS SPECIFIC CONFIGURATIONS WHEN IT COMES TO CORRECT TUBE AND TRANSFORMER SETUP.

The illustrations below show the various configurations that are possible when using the T3 Wandlite.

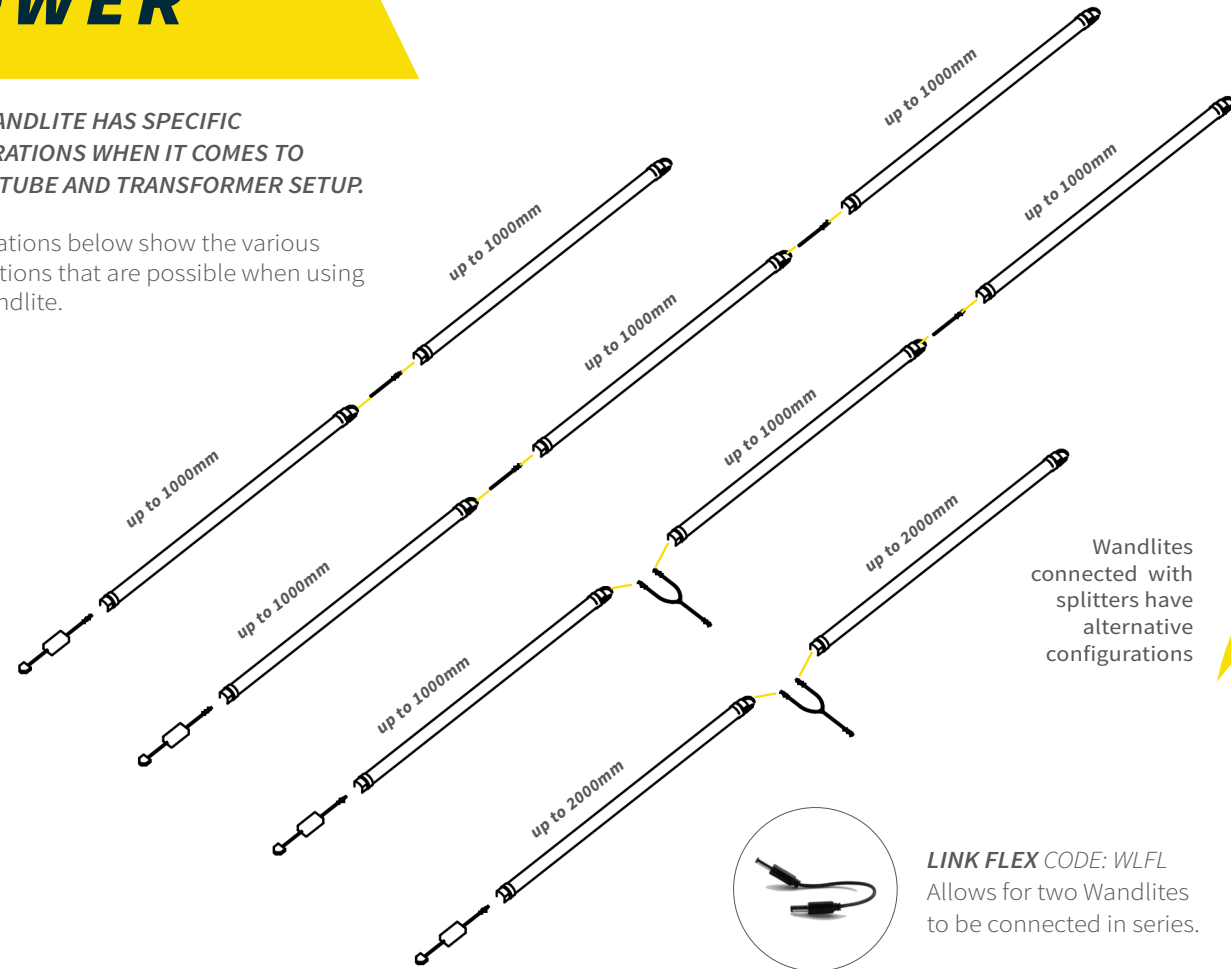

Wandlites connected with splitters have alternative configurations



LINK FLEX CODE: WLFL
Allows for two Wandlites to be connected in series.



SPLITTER FLEX CODE: WLFS
Allows for two Wandlites to be connected independently.



TRANSFORMERS CODE: WLT5 / 8
Available in 2Amp / 5Amp / 8Amp

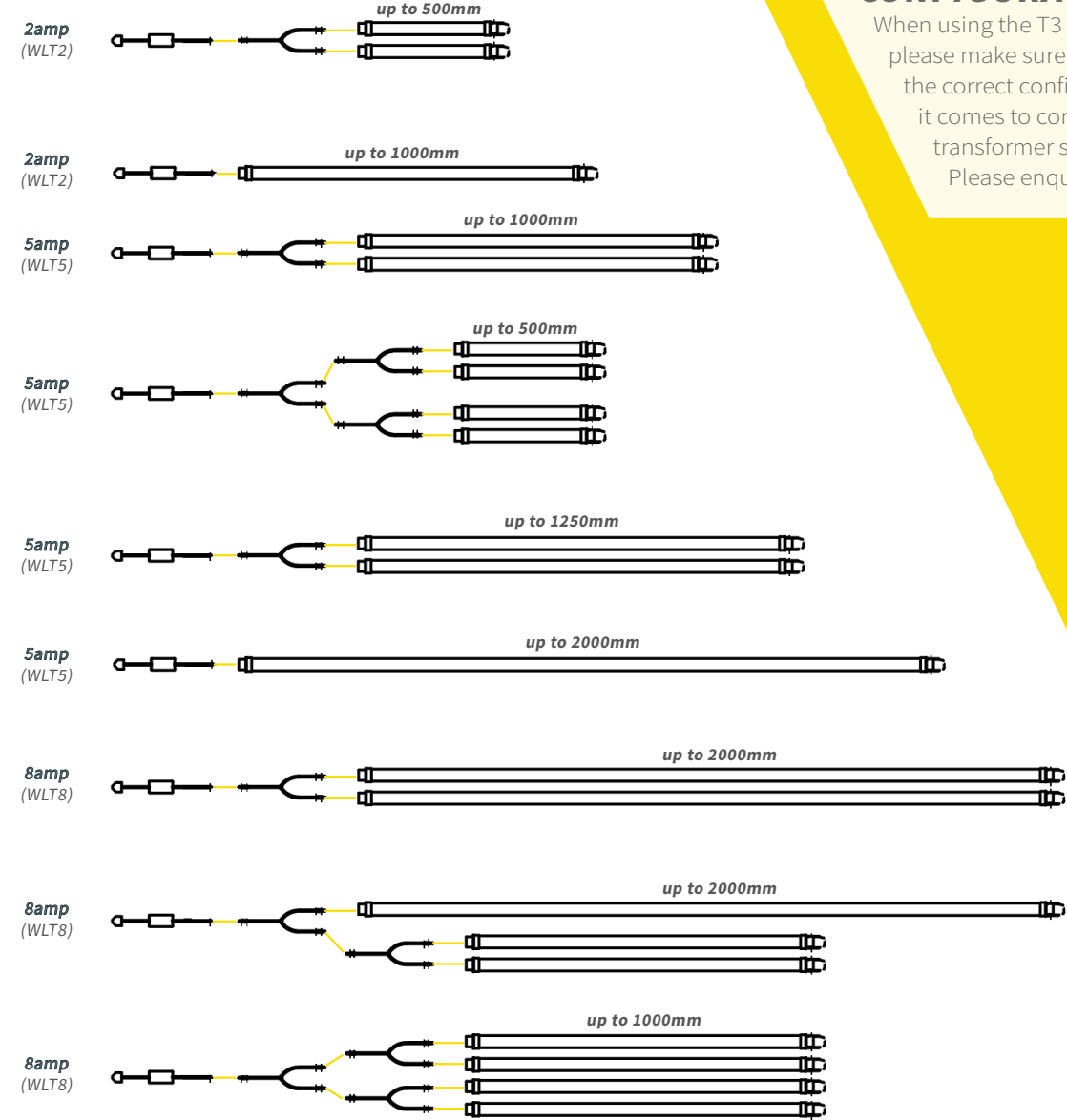

CONFIGURATIONS

When using the T3 Wandlight, please make sure that you use the correct configurations when it comes to correct tube and transformer setup. Please enquire for more details.

ACCESSORIES

THE T3 WANDLITE HAS MULTIPLE ACCESSORIES THAT ARE SPECIALLY DEVELOPED FOR EVERY LIGHTING NEED.

With so many lighting requirements within the display industry, the T3 Wandlite has specially developed accessories that can be used to make it the revolutionary solution for every need.

RGB CONTROLLER

CODE: WLBC

This controller allows you to input a variety of colouring functions into your T3 Wandlite. This provides you with the unique corporate branding



SUSPENSION HOOKS

CODE: WLCSH

Clip onto the end fitting of each T3 Wandlite. It provides the platform for multiple tubes to be linked together or, for the suspension of Wandlite's using hooks.



TWIST IN SHELF SUPPORT

CODE: CHSST

Twist directly into the the T3 Frame Channel profiles. It provides the platform for the



i INFO

Make use of twist-in supports, suspension hooks and 'C' hooks as the most versatile installation method.

KEY FEATURE

Include coloured RGB T3 Wandlight into your display to create a unique ambient display.

GET IN TOUCH



EMAIL

sales@tecnadisplay.com



CALL

UK OFFICE: +44 (0)208 803 4469
USA OFFICE: +1 (310) 299-2789



WWW.T3SYSTEMS.COM

